

## PINZE PER TRONCHI

LOG GRABS  
GRAPPIN À BOIS  
STAMMGREIFER





**GHEDINI**  
ATTACHMENTS

# Serie KA • KA Series • Série KA • Serie KA

PER MINI - MIDI ESCAVATORI FINO A 15 TON • FOR MINI AND MIDI EXCAVATORS UP TO 15 T  
POUR MINI ET MIDI PELLE JUSQU'À 15 T • FÜR MINI UND MIDI BAGGER BIS 15 T



 Pinze per tronchi ideali per la movimentazione, il carico e lo scarico di tronchi d'albero ripuliti dai rami e pronti per il trasporto: possono essere montate sulle gru forestali di tutte le gamme e dimensioni. E' costruita in acciaio domex 710 e munita di valvola di blocco. Trovano impiego in ambito forestale ed industriale, per escavatori fino a 15 ton.

 Log grabs suitable for the handling, the loading and the unloading of the logs ready to be transported. They can be mounted on excavators or forestry cranes. They are built of steel Domex 710 and equipped with blocking valves.

 Grappins à bois idéales pour le mouvement, le chargement et le déchargement du troncs d'arbre, nettoyés et prêts pour le transport. Ils peuvent être montés sur pelles ou grues forestières. Fabriqués en acier Domex 710 et équipés avec soupapes d'arrêt

 Stammgreifer geeignet für das Halten, Laden und Ausladen von Stämmen. Sie können an Bagger und an Forstkräne montiert werden. Sie sind aus Domex 710 Stahl gebaut und mit Blockventilen ausgestattet.



PINZE PER TRONCHI  
LOG GRABS

**PARTICOLARI PINZE PER TRONCHI DI SERIE • FEATURES STANDARD LOG GRABS**  
**CHARACTERISTIQUES GRAPPIN À BOIS • EIGENSCHAFTEN STANDARD STAMMGREIFER**

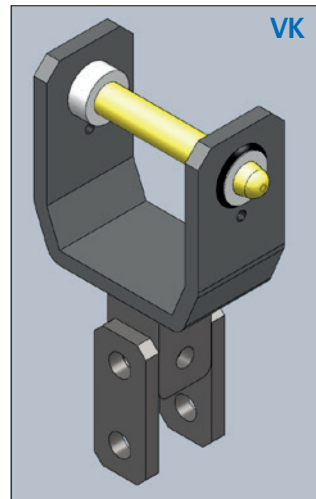

Possibilità di attacco a doppio perno oppure per aggancio rapido

*Possibility coupling double pin or for quick hitch.*

Possibilit  attache deux axes ou pour attache rapide

*M glichkeit Aufnahme zwei Bolzen oder f r SWE*

**ROTATORE IDRAULICO A 360° ILLIMITATO**  
**HYDRAULIC ROTATOR 360°**  
**ROTATEUR HYDRAULIQUE   360° ILLIMIT **  
**HYDRAULISCHES DREHGELENK 360°**

**SELLA DI ATTACCO AL BRACCIO 1 PERNO • BRACKET 1 PIN**  
**ATTACHE AU BRAS 1 AXE • AUFNAHME 1 BOLZEN**

Modello Model Mod�le Modell	Portata max statica Max static load Charge statique maxi Max. statische Ladung	Peso Weight Poids Gewicht
AR 12 P	1,2 ton	10 kg
AR 35 P	3,5 ton	17 kg
AR 50 P	5,0 ton	25 kg
AR 70 P	7,0 ton	36 kg
AR 120 P	12 ton	48 kg
AR 125 F	12 ton	56 kg
AR 175 F	17 ton	70 kg

Modello Model Mod�le Modell	Peso escavatore Excavator weight Poids de la pelle Gewicht des Baggers
VK 01	1-2 ton.
VK 02	2-4 ton.
VK 03	4-7 ton.
VK 04	7-15 ton.

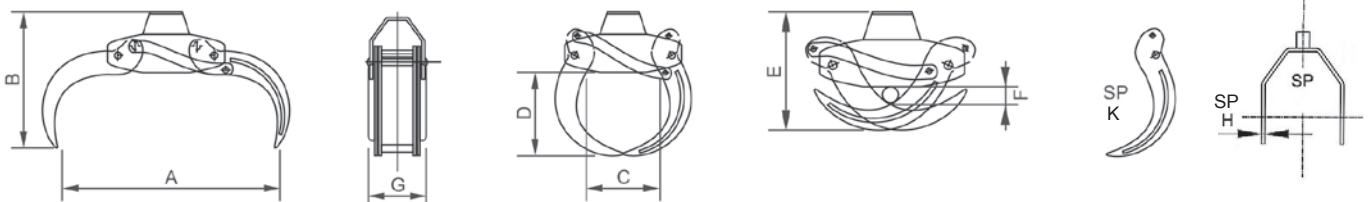

Per pressioni superiori ai 250 BAR viene montata una valvola MASSIMA KX05 (optional) • For pressure higher than 250 bar, a MAXIMUM valve will be mounted KX05 (upon request)  
 Pour pressions sup rieures   250 Bar, il sera mont  une soupape MAXI KX05 (Sur demande) • F r Druck mehr als 250 Bar, ein MAXIMUM Ventil wird montiert KX05 (Auf Wunsch)

**CARATTERISTICHE TECNICHE • TECHNICAL DETAILS • DONNEES TECHNIQUES • TECHNISCHE EIGENSCHAFTEN**

Modello Model Mod�le Modell	Peso Weight Poids Gewicht	Max bar	Capacit� sollevamento Lifting capacity Capacit� de levage Hubkraft	A mm	B mm	C mm	D mm	E mm	F mm	G mm	SP H mm	SP K mm	Area mq m <sup>2</sup> area Surface m <sup>2</sup> m <sup>2</sup> Fl�che	Peso escavatore Excavator weight Poids de la pelle Gewicht des Baggers	Rotatore consigliato Rotator recommended Rotateur conseill� Berater Drehgelenk
KA 08	60 kg	210	1000	1000	730	405	450	460	65	310	10	8	0,146	0,8 / 1,8 ton	AR 12 P
KA 10	89 kg	250	1400	1000	730	405	450	460	65	310	20	10	0,146	1,9 / 3,0 ton	AR 35 P
KA 12	110 kg	250	1700	1200	770	450	480	510	80	355	20	10	0,201	3,0 / 5,0 ton	AR 50 P
KA 13	155 kg	250	2100	1350	880	500	540	550	90	370	20	12	0,255	4,0 / 7,0 ton	AR 70 P
KA 15	240 kg	250	2700	1550	960	620	630	600	100	430	20	12	0,336	7,0 / 10,0 ton	AR 120 P
KA 15 H	314 kg	350	2900	1550	960	620	630	600	100	430	20	15	0,336	10,0 / 15,0 ton	AR 125 F
KA 17 H	400 kg	350	3400	1750	1100	680	710	670	150	490	20	20	0,428	13,0 / 15,0 ton	AR 175 F



**Ghedini ing. Fabio & C. s.a.s.**

Via Canne, 47 - 44048 Argenta (Ferrara) Italy

Tel. +39 0532 857373 - Fax +39 0532 2845032

e-mail Italia: info@ghedini.com - Export: alessandra@ghedini.com

[www.ghedini.com](http://www.ghedini.com)

